

(No Model.)

W. VON PITTLER.
TURNING LATHE.

No. 507,283.

Patented Oct. 24, 1893.

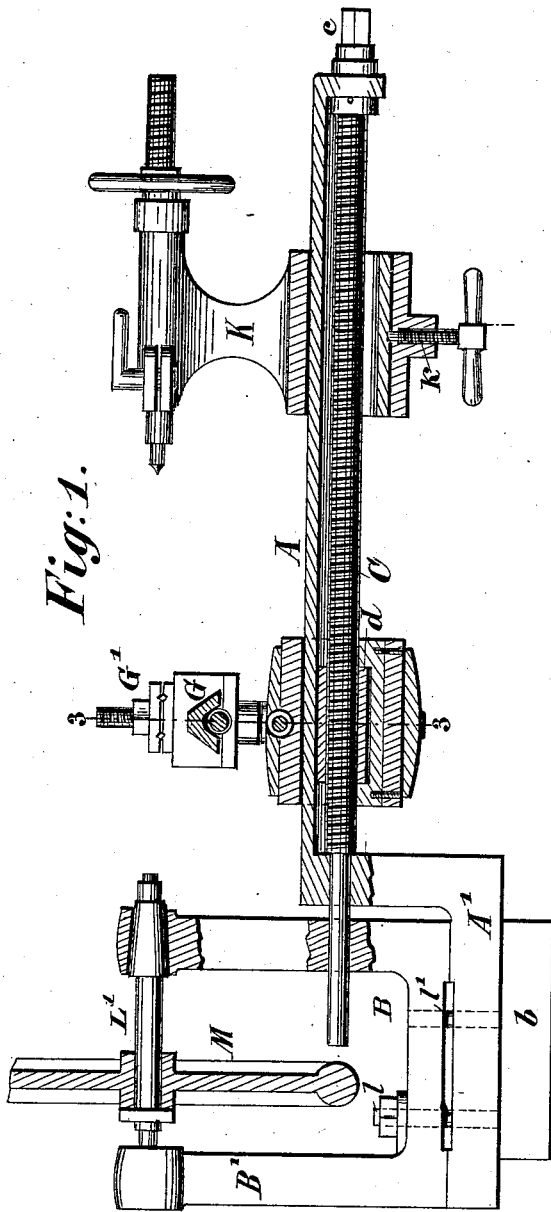

Fig. 1.

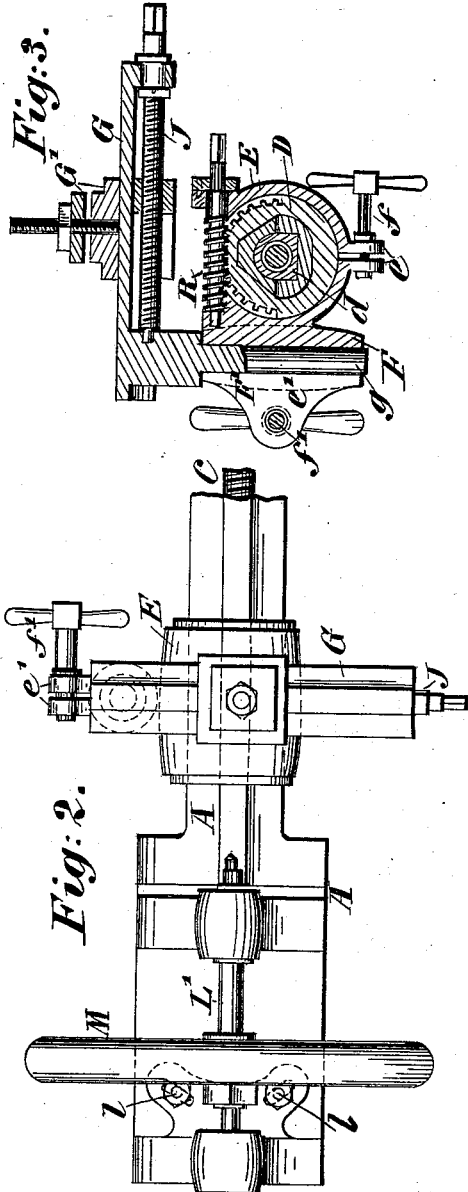

Fig. 3.

Fig. 2.

WITNESSES:

Charles Schroeder
Adolph Scherer

INVENTOR

W. von Pittler

BY *Georgel Rechner*

ATTORNEYS.

UNITED STATES PATENT OFFICE.

WILHELM VON PITTLER, OF LEIPSI-GOHLIS, GERMANY.

TURNING-LATHE.

SPECIFICATION forming part of Letters Patent No. 507,283, dated October 24, 1893.

Application filed June 9, 1892. Serial No. 436,058. (No model.) Patented in Germany February 7, 1889, No. 50,246, and May 7, 1890, No. 51,989; in England May 20, 1889, No. 8,374, and January 1, 1890, No. 1,358; in Belgium December 13, 1889, No. 88,835, and February 4, 1890, No. 89,399, and in Austria-Hungary October 24, 1890, No. 21,190 and No. 44,853, and October 25, 1890, No. 16,561 and No. 34,592.

To all whom it may concern:

Be it known that I, WILHELM VON PITTLER, a citizen of the Empire of Germany, and a resident of Leipsic-Gohlis, in the Empire of Germany, have invented certain new and useful Improvements in Turning-Lathes, (for which I have obtained Letters Patent in the following countries: Austria-Hungary, October 24, 1890, No. 21,190 and No. 44,853, and October 25, 1890, No. 16,561 and No. 34,592; Germany, February 7, 1889, No. 50,246, and May 7, 1890, No. 51,989; England, May 20, 1889, No. 8,374, and January 1, 1890, No. 1,358; Belgium, February 4, 1890, No. 89,399, and December 13, 1889, No. 88,835,) of which the following is a specification.

The object of my invention is to provide a new and improved metal-working machine which is adapted for turning, milling, drilling, &c., and is especially adapted for small shops, locksmiths, blacksmiths, grinders, tool-makers, watch-makers, &c.

In the accompanying drawings, Figure 1 is a vertical longitudinal sectional view of my improved metal-working machine. Fig. 2 is a top-view of the head-stock and slide-rest. Fig. 3 is a vertical transverse sectional view of the slide-rest, on the line 3 3, of Fig. 1.

Similar letters of reference indicate corresponding parts.

The combined bed and guide-rail A on which the tail-stock and slide-rest can slide is prismatic in cross-section and is provided with an L-shaped extension A' having a suitable projection or boss b on the under side, by means of which said combined bed and guide-rail A can be held between the jaws of a vise or fastened to a bench as may be desired. On the said extension A' the head-stock frame B is fastened and held by means of a pivot l' and two screws l, thus permitting of giving the head-stock frame B any desired inclination and locking it in place after adjustment, as, for example, is shown in Fig. 2 in dotted lines. The rail A is provided in its under side with a longitudinal recess which contains the screw-spindle C that is provided at one end with a square head c for applying

a key or other implement for turning it, the opposite end of said spindle terminating in the smooth part that turns in a suitable bearing. The tail-stock K is adapted to slide on the bed-rail and can be locked in place by means of the clamping-screw k in the usual manner. The slide-rest is constructed with a block D containing the nut d through which the screw-spindle C passes, said block D being provided with sunken cogs in its rim, which cogs are shown only on half the diameter in the section Fig. 3, and said cogs engage a transverse screw-spindle R, which spindle is mounted in the top of the sleeve E surrounding the block D, and the spindle is provided at one end with a squared head for applying a key for turning it. The sleeve E has two lugs e, into which a clamping screw f is screwed, by means of which said sleeve can be clamped securely on the block D. The sleeve E is also provided with an extension F having a vertical split sleeve having two wings e' into which the clamping screw f' is screwed that serves for clamping said split sleeve F' on the pivot g, which forms part of and projects downward from the top rail or bar G of the slide-rest. On said rail G the tool-holding clamp G' is mounted to slide, and can be shifted lengthwise by means of a screw-spindle J arranged in a longitudinal recess in the under side of said supporting rail G, which spindle J engages the nut h connected with the tool-holding clamp G'. By turning the screw-spindle R, after having loosened the screw f, the slide-rest can be turned around the spindle C to have any desired inclination, and when the screw f' in the sleeve F' is loosened the slide-rest G can be turned horizontally on its pivot g. The tool-clamp or holder G' may have any desired shape, according to the shape of the tool that is to be held or the shape of the article to be acted upon, &c.

On account of the great adjustability of the slide-rest, the machine can be used for various purposes, such as turning metal, milling or drilling. In drilling, the article to be drilled is held in the slide-rest and the bit or drill is

screwed on the end of the driving or fly-wheel shaft L'. In a like manner the machine can be used for milling, the milling tools being applied on the shaft L' and the piece to be milled held on the slide-rest, which can readily be adjusted in a proper position for the milling operation.

Having thus described my invention, I claim as new and desire to secure by Letters Patent—

1. In a metal-working machine, the combination with a bed-rail, of a spindle in the same, a nut on the spindle, a block surrounding the nut and having teeth in its rim, a sleeve surrounding the block and adapted to be clamped on the same, a rail supported on said block

and a tool-support on said rail, substantially as set forth.

2. In a metal working machine, the combination, with a spindle, of a nut mounted to slide on the same, a block surrounding said nut and provided with teeth in its rim, a sleeve surrounding said block, and tool-holding devices supported by said sleeve, substantially as set forth.

In testimony that I claim the foregoing as my invention I have signed my name in presence of two subscribing witnesses.

WILHELM VON PITTLER.

Witnesses:

HENRY W. DIEDERICH,
CARL BORNGRAEBER.